

# LOW VOLTAGE, LVCMOS/LVPECL-TO LVPECL/ECL CLOCK GENERATOR

ICS873991-147

## GENERAL DESCRIPTION



The ICS873991-147 is a low voltage, low skew, 3.3V LVPECL or ECL Clock Generator and a member of the HiPerClockS™ family of High Performance Clock Solutions from IDT. The ICS873991-147 has two selectable clock inputs. The PCLK, nPCLK pair can accept an LVPECL input and the REF\_CLK pin can accept a LVCMOS or LVTTTL input. This device has a fully integrated PLL along with frequency configurable outputs. An external feedback input and output regenerates clocks with “zero delay”.

The four independent banks of outputs each have their own output dividers, which allow the device to generate a multitude of different bank frequency ratios and output-to-input frequency ratios. The output frequency range is 25MHz to 500MHz and the input frequency range is 6.25MHz to 125MHz. The PLL\_SEL input can be used to bypass the PLL for test and system debug purposes. In bypass mode, the input clock is routed around the PLL and into the internal output dividers.

The ICS873991-147 also has a SYNC output which can be used for system synchronization purposes. It monitors Bank A and Bank C outputs for coincident rising edges and signals a pulse per the timing diagrams in this data sheet. This feature is used primarily in applications where Bank A and Bank C are running at different frequencies, and is particularly useful when they are running at non-integer multiples of each other.

### Example Applications:

1. Line Card Multiplier: Multiply 19.44MHz from a back-plane to 77.76MHz on the line card ASIC and Serdes.
2. Zero Delay Buffer: Fan out up to thirteen 100MHz copies from a reference clock to multiple processing units on an embedded system.

## FEATURES

- Fourteen differential 3.3V LVPECL/ECL outputs
- Selectable differential LVPECL or REF\_CLK inputs
- PCLK, nPCLK can accept the following input levels: LVPECL, CML, SSTL
- REF\_CLK accepts the following input levels: LVCMOS, LVTTTL
- Input clock frequency range: 6.25MHz to 125MHz
- Maximum output frequency: 500MHz
- VCO range: 200MHz to 1GHz
- Output skew: 70ps (typical)
- Cycle-to-cycle jitter: 35ps (typical)
- LVPECL mode operating voltage supply range:  $V_{CC} = 3.135V$  to  $3.465V$ ,  $V_{EE} = 0V$
- ECL mode operating voltage supply range:  $V_{CC} = 0V$ ,  $V_{EE} = -3.465V$  to  $-3.135V$
- 0°C to 70°C ambient operating temperature
- Available in lead-free (RoHS 6) package
- Industrial temperature available upon request

## PIN ASSIGNMENT

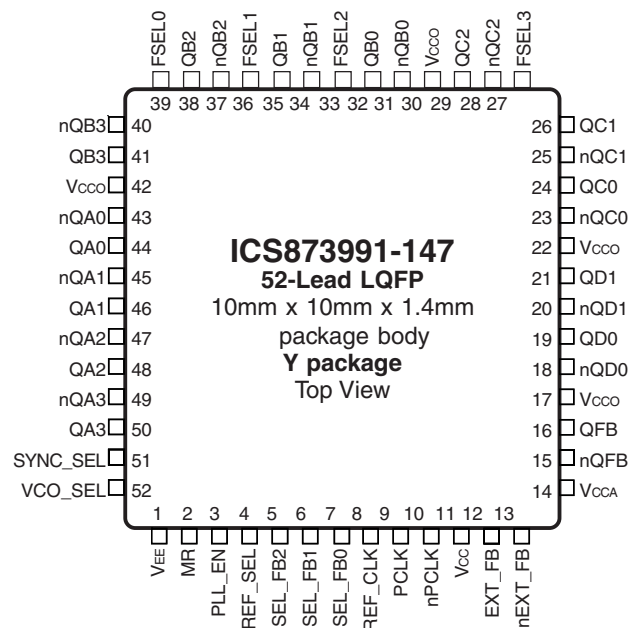

The Preliminary Information presented herein represents a product in pre-production. The noted characteristics are based on initial product characterization and/or qualification. Integrated Device Technology, Incorporated (IDT) reserves the right to change any circuitry or specifications without notice.

### BLOCK DIAGRAM

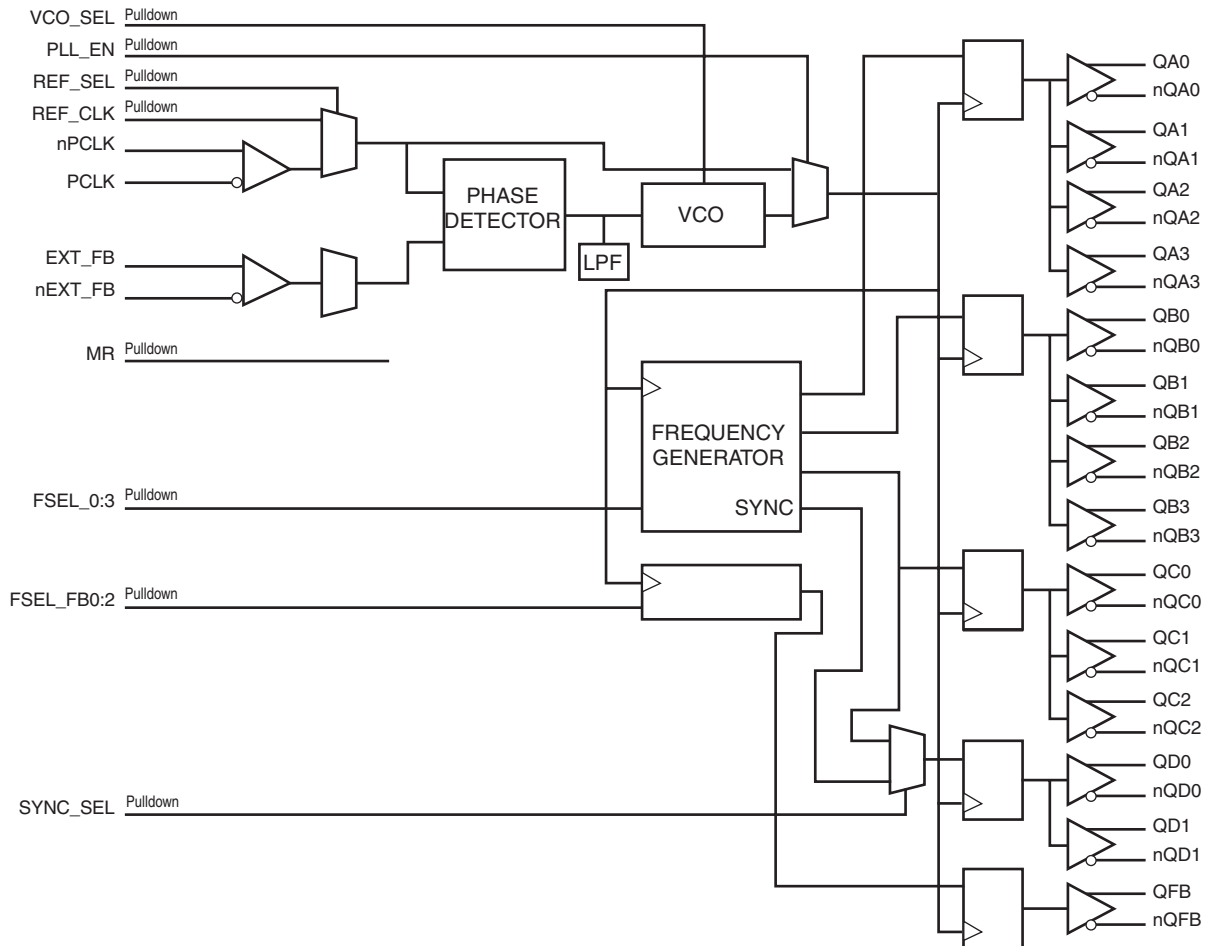

TABLE 1. PIN DESCRIPTIONS

Number	Name	Type		Description
1	V <sub>EE</sub>	Power		Negative supply pin.
2	MR	Input	Pulldown	Active High Master Reset. When logic HIGH, the internal dividers are reset causing the true outputs (Qx) to go low and the inverted outputs (nQx) to go high. When logic LOW, the internal dividers and the outputs are enabled. LVCMOS/LVTTL interface levels.
3	PLL_EN	Input	Pulldown	PLL enable pin. When logic LOW, PLL is enabled. When logic HIGH, PLL is in bypass mode. LVCMOS/LVTTL interface levels.
4	REF_SEL	Input	Pulldown	Selects between the different reference inputs as the PLL reference source. When logic LOW, selects PCLK/nPCLK. When logic HIGH, selects REF_CLK. LVCMOS/LVTTL interface levels.
5	FSEL_FB2	Input	Pulldown	Feedback frequency select pins. LVCMOS/LVTTL interface levels.
6	FSEL_FB1			
7	FSEL_FB0			
8	REF_CLK	Input	Pulldown	Reference clock input. LVCMOS/LVTTL interface levels.
9	PCLK	Input	Pulldown	Non-inverting differential LVPECL clock input.
10	nPCLK	Input	Pullup/ Pulldown	Inverting differential LVPECL clock input. V <sub>CC</sub> /2 default when left floating.
11	V <sub>CC</sub>	Power		Core supply pin.
12	EXT_FB	Input	Pulldown	Non-inverting external feedback input.
13	nEXT_FB	Input	Pullup/ Pulldown	Inverting external feedback input. V <sub>CC</sub> /2 default when left floating.
14	V <sub>CCA</sub>	Power		Analog supply pin.
15	nQFB	Output		Differential feedback output pair. LVPECL Interface levels.
16	QFB			
17, 22, 30, 42	V <sub>CCO</sub>	Power		Output supply pins.
18, 19	nQD0, QD0	Output		Differential output pair. LVPECL interface levels.
20, 21	nQD1, QD1	Output		Differential output pair. LVPECL interface levels.
23, 24	nQC0, QC0	Output		Differential output pair. LVPECL interface levels.
25, 26	nQC1, QC1	Output		Differential output pair. LVPECL interface levels.
27	FSEL3	Input	Pulldown	Frequency select pins. LVCMOS/LVTTL interface levels.
33	FSEL2			
36	FSEL1			
39	FSEL0			
28, 29	nQC2, QC2	Output		Differential output pair. LVPECL interface levels.
31, 32	nQB0, QB0	Output		Differential output pair. LVPECL interface levels.
34, 35	nQB1, QB1	Output		Differential output pair. LVPECL interface levels.
37, 38	nQB2, QB2	Output		Differential output pair. LVPECL interface levels.
40, 41	nQB3, QB3	Output		Differential output pair. LVPECL interface levels.
43, 44	nQA0, QA0	Output		Differential output pair. LVPECL interface levels.
45, 46	nQA1, QA1	Output		Differential output pair. LVPECL interface levels.
47, 48	nQA2, QA2	Output		Differential output pair. LVPECL interface levels.
49, 50	nQA3, QA3	Output		Differential output pair. LVPECL interface levels.
51	SYNC_SEL	Input	Pulldown	SYNC output select pin. When LOW, the SYNC output follows the timing diagram (page 5). When HIGH, QD output follows QC output LVCMOS/LVTTL interface levels..
52	VCO_SEL	Input	Pulldown	Selects VCO range. LVCMOS/LVTTL interface levels.

NOTE: Pullup and Pulldown refer to internal input resistors. See Table 2, Pin Characteristics, for typical values.

TABLE 2. PIN CHARACTERISTICS

Symbol	Parameter	Test Conditions	Minimum	Typical	Maximum	Units
$C_{IN}$	Input Capacitance			4		pF
$R_{PULLDOWN}$	Input Pulldown Resistor			51		k $\Omega$
$R_{PULLUP}$	Input Pullup Resistor			51		k $\Omega$

TABLE 3A. SELECT PIN FUNCTION TABLE

Inputs				Outputs		
FSEL3	FSEL2	FSEL1	FSEL0	QAx	QBx	QCx
0	0	0	0	$\div 2$	$\div 2$	$\div 2$
0	0	0	1	$\div 2$	$\div 2$	$\div 4$
0	0	1	0	$\div 2$	$\div 4$	$\div 4$
0	0	1	1	$\div 2$	$\div 2$	$\div 6$
0	1	0	0	$\div 2$	$\div 6$	$\div 6$
0	1	0	1	$\div 2$	$\div 4$	$\div 6$
0	1	1	0	$\div 2$	$\div 4$	$\div 8$
0	1	1	1	$\div 2$	$\div 6$	$\div 8$
1	0	0	0	$\div 2$	$\div 2$	$\div 8$
1	0	0	1	$\div 2$	$\div 8$	$\div 8$
1	0	1	0	$\div 4$	$\div 4$	$\div 6$
1	0	1	1	$\div 4$	$\div 6$	$\div 6$
1	1	0	0	$\div 4$	$\div 6$	$\div 8$
1	1	0	1	$\div 6$	$\div 6$	$\div 8$
1	1	1	0	$\div 6$	$\div 8$	$\div 8$
1	1	1	1	$\div 8$	$\div 8$	$\div 8$

TABLE 3B. FEEDBACK CONTROL FUNCTION TABLE

Inputs			Outputs
FSEL_FB2	FSEL_FB1	FSEL_FB0	QFB
0	0	0	$\div 2$
0	0	1	$\div 4$
0	1	0	$\div 6$
0	1	1	$\div 8$
1	0	0	$\div 8$
1	0	1	$\div 16$
1	1	0	$\div 24$
1	1	1	$\div 32$

TABLE 3C. INPUT CONTROL FUNCTION TABLE

Control Input Pin	Logic 0	Logic 1
PLL_EN	Enables PLL	Bypasses PLL
VCO_SEL	fVCO	fVCO/2
REF_SEL	Selects PCLK/nPCLK	Selects REF_CLK
MR	---	Resets outputs
SYNC_SEL	Selects outputs	Match QC Outputs

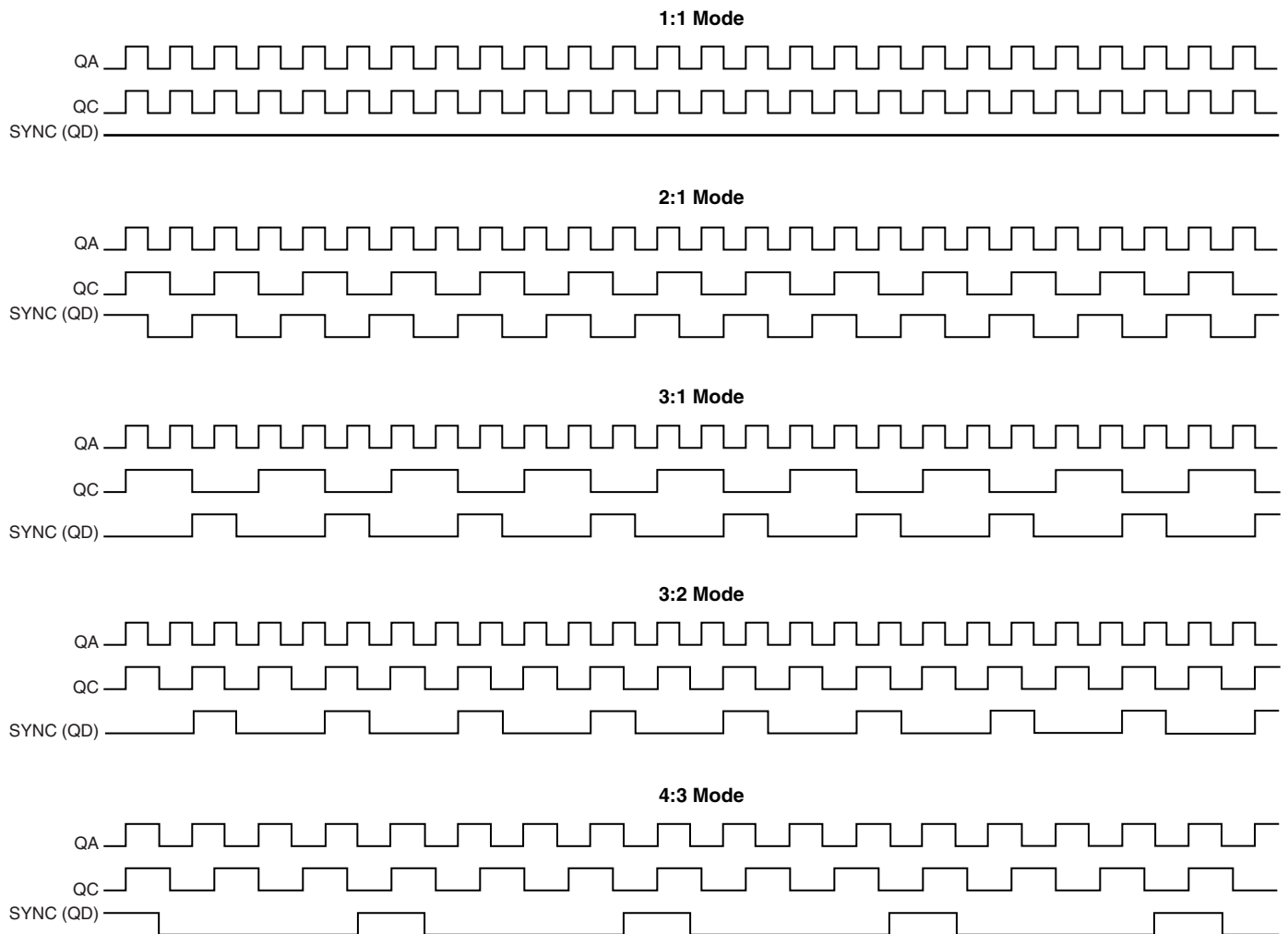

FIGURE 1. TIMING DIAGRAMS

**ABSOLUTE MAXIMUM RATINGS**

Supply Voltage, $V_{CC}$	4.6V
Inputs, $V_I$	-0.5V to $V_{CC} + 0.5$ V
Outputs, $I_O$	
Continuous Current	50mA
Surge Current	100mA
Package Thermal Impedance, $\theta_{JA}$	63.7°C/W (0 mps)
Storage Temperature, $T_{STG}$	-65°C to 150°C

**NOTE:** Stresses beyond those listed under Absolute Maximum Ratings may cause permanent damage to the device. These ratings are stress specifications only. Functional operation of product at these conditions or any conditions beyond those listed in the *DC Characteristics* or *AC Characteristics* is not implied. Exposure to absolute maximum rating conditions for extended periods may affect product reliability.

**TABLE 4A. POWER SUPPLY DC CHARACTERISTICS,  $V_{CC} = V_{CCA} = V_{CCO} = 3.3V \pm 5\%$ ,  $V_{EE} = 0V$ ,  $T_A = 0^\circ C$  TO  $70^\circ C$** 

Symbol	Parameter	Test Conditions	Minimum	Typical	Maximum	Units
$V_{CC}$	Core Supply Voltage		3.135	3.3	3.465	V
$V_{CCA}$	Analog Supply Voltage		3.135	3.3	3.465	V
$V_{CCO}$	Output Supply Voltage		3.135	3.3	3.465	V
$I_{CC}$	Power Supply Current				150	mA
$I_{CCA}$	Analog Supply Current				15	mA
$I_{CCO}$	Output Supply Current				95	mA

**TABLE 4B. LVCMOS/LVTTL DC CHARACTERISTICS,  $V_{CC} = V_{CCA} = V_{CCO} = 3.3V \pm 5\%$ ,  $V_{EE} = 0V$ ,  $T_A = 0^\circ C$  TO  $70^\circ C$** 

Symbol	Parameter	Test Conditions	Minimum	Typical	Maximum	Units
$V_{IH}$	Input High Voltage	PLL_EN, VCO_SEL, REF_SEL, SYNC_SEL, FSEL_FB0:FSEL_FB2, FSEL0:FSEL3, MR	2		$V_{CC} + 0.3$	V
		REF_CLK	2		$V_{CC} + 0.3$	V
$V_{IL}$	Input Low Voltage	PLL_EN, VCO_SEL, REF_SEL, SYNC_SEL, FSEL_FB0:FSEL_FB2, FSEL0:FSEL3, MR	-0.3		0.8	V
		REF_CLK	-0.3		1.3	V
$I_{IH}$	Input High Current	$V_{CC} = V_{IN} = 3.465V$			150	$\mu A$
$I_{IL}$	Input Low Current	$V_{IN} = 0V$ , $V_{CC} = 3.465V$	-5			$\mu A$

**TABLE 4C. LVPECL DC CHARACTERISTICS,  $V_{CC} = V_{CCA} = V_{CCO} = 3.3V \pm 5\%$ ,  $V_{EE} = 0V$ ,  $T_A = 0^\circ C$  TO  $70^\circ C$** 

Symbol	Parameter	Test Conditions	Minimum	Typical	Maximum	Units
$I_{IH}$	Input High Current	PCLK	$V_{CC} = V_{IN} = 3.465V$		150	$\mu A$
		nPCLK	$V_{CC} = V_{IN} = 3.465V$		5	$\mu A$
$I_{IL}$	Input Low Current	PCLK	$V_{CC} = 3.465V$ , $V_{IN} = 0V$	-5		$\mu A$
		nPCLK	$V_{CC} = 3.465V$ , $V_{IN} = 0V$	-150		$\mu A$
$V_{PP}$	Peak-to-Peak Input Voltage		0.3		1	V
$V_{CMR}$	Common Mode Input Voltage; NOTE 1		$V_{EE} + 1.5$		$V_{CC}$	V
$V_{OH}$	Output High Voltage; NOTE 2		$V_{CC} - 1.4$		$V_{CC} - 0.9$	V
$V_{OL}$	Output Low Voltage; NOTE 2		$V_{CC} - 2.0$		$V_{CC} - 1.7$	V
$V_{SWING}$	Peak-to-Peak Output Voltage Swing		0.6		1	V

NOTE 1: Common mode voltage is defined as  $V_{IH}$ .

NOTE 2: Outputs terminated with 50 $\Omega$  to  $V_{CCO} - 2V$ .

TABLE 5. PLL INPUT REFERENCE CHARACTERISTICS,  $V_{CC} = V_{CCA} = V_{CCO} = 3.3V \pm 5\%$ ,  $T_A = 0^\circ C$  TO  $70^\circ C$ 

Symbol	Parameter	Test Conditions	Minimum	Typical	Maximum	Units
$t_R / t_F$	Input Rise/Fall Time	REF_CLK			3	ns
$f_{REF}$	Reference Frequency VCO_SEL = 0	Feedback $\div$ 6	66.66		166.67	MHz
		Feedback $\div$ 8	50		125	MHz
		Feedback $\div$ 16	25		62.5	MHz
		Feedback $\div$ 24	16.66		41.67	MHz
		Feedback $\div$ 32	12.5		31.25	MHz
	Reference Frequency VCO_SEL = 1	Feedback $\div$ 4	50		100	MHz
		Feedback $\div$ 6	33.33		66.66	MHz
		Feedback $\div$ 8	25		50	MHz
		Feedback $\div$ 16	12.5		25	MHz
		Feedback $\div$ 24	8.33		16.66	MHz
	Feedback $\div$ 32	6.25		12.5	MHz	
$f_{REFDC}$	Reference Input Duty Cycle		25		75	%

NOTE: These parameters are guaranteed by design, but are not tested in production.

TABLE 6. AC CHARACTERISTICS,  $V_{CC} = V_{CCA} = V_{CCO} = 3.3V \pm 5\%$ ,  $T_A = 0^\circ C$  TO  $70^\circ C$ 

Symbol	Parameter	Test Conditions	Minimum	Typical	Maximum	Units
$f_{MAX}$	Output Frequency	QA, QB, QC			500	MHz
		QD	SYNC_SEL = 1		400	MHz
		QD; NOTE 1	SYNC_SEL = 0		200	MHz
$t(\emptyset)$	Static Phase Offset; NOTE 2, 3	PCLK, nPCLK		170		ps
$t_{sk(o)}$	Output Skew; NOTE 4, 5			70		ps
$t_{sk(w)}$	Multiple Frequency Skew; NOTE 5, 6			TBD		ps
$f_{jit(cc)}$	Cycle-to-Cycle Jitter; NOTE 5			35		ps
$f_{VCO}$	PLL VCO Lock Range; NOTE 7	PLL_SEL = 0	0.4		1.0	GHz
		PLL_SEL = 1	200		480	MHz
$t_{LOCK}$	PLL Lock Time				10	ms
$t_R / t_F$	Output Rise/Fall Time	20% to 80%		0.5		ns
odc	Output Duty Cycle			50		%

All parameters measured at  $f_{MAX}$  unless noted otherwise.

NOTE 1: SYNC output (QD when SYNC\_SEL = 0) operation guaranteed to 800MHz maximum VCO frequency.

NOTE 2: Defined as the time difference between the input reference clock and the average feedback input signal when the PLL is locked and the input reference frequency is stable.

NOTE 3: Static phase offset is specified for an input frequency of 50MHz with feedback in  $\div 8$ .

NOTE 4: Defined as skew between outputs at the same supply voltage and with equal load conditions.

Measured at the output differential cross points.

NOTE 5: This parameter is defined in accordance with JEDEC Standard 65.

NOTE 6: Defined as skew across banks of outputs switching in the same direction operating at different frequencies with the same supply voltages and equal load conditions. Measured at  $V_{CCO}/2$ .

NOTE 7: When VCO\_SEL = 0, the PLL will be unstable with feedback configurations of  $\div 2$ ,  $\div 4$  and some  $\div 6$ .

When VCO\_SEL = 1, the PLL will be unstable with a feedback configuration of  $\div 2$ .

## PARAMETER MEASUREMENT INFORMATION

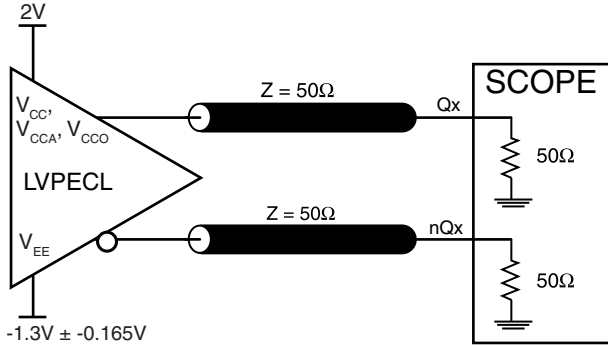

OUTPUT LOAD AC TEST CIRCUIT

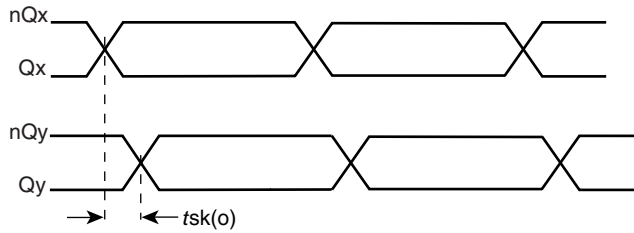

OUTPUT SKEW

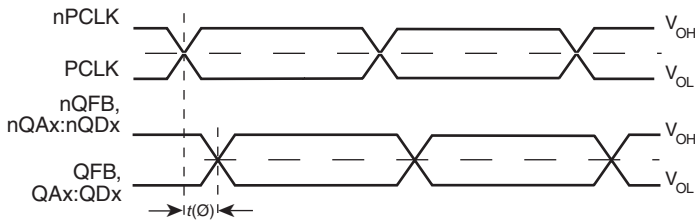

STATIC PHASE OFFSET

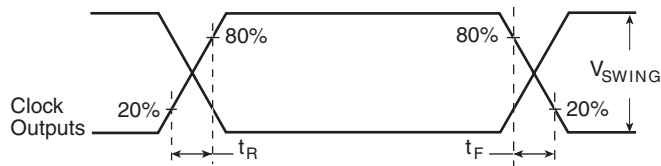

OUTPUT RISE/FALL TIME

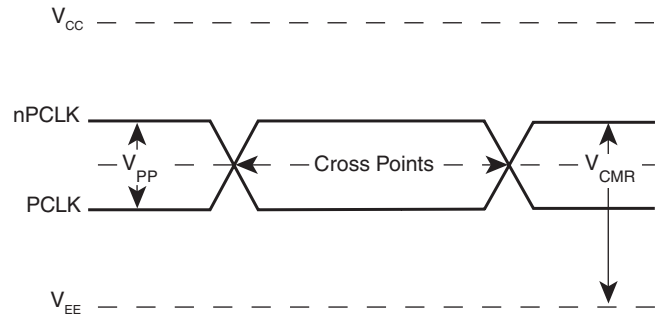

DIFFERENTIAL INPUT LEVELS

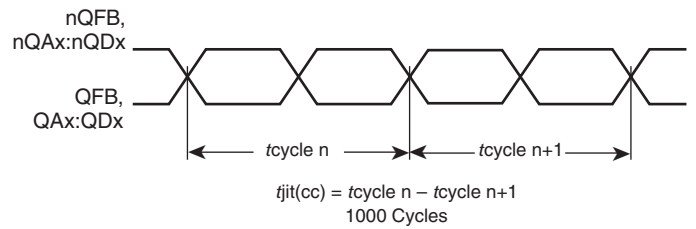

CYCLE-TO-CYCLE JITTER

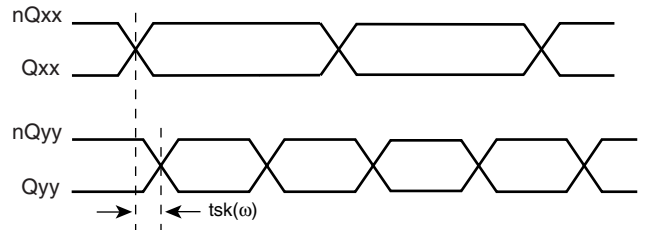

MULTIPLE FREQUENCY SKEW

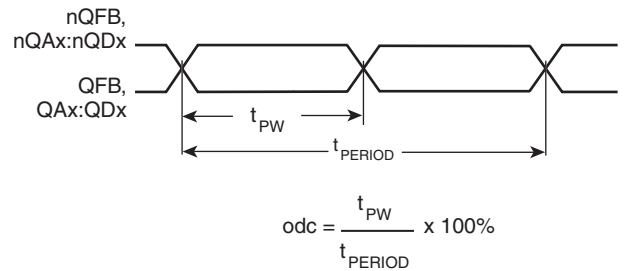

OUTPUT DUTY CYCLE/PULSE WIDTH/PERIOD



## APPLICATIONS INFORMATION

### POWER SUPPLY FILTERING TECHNIQUES

As in any high speed analog circuitry, the power supply pins are vulnerable to random noise. The ICS873991-147 provides separate power supplies to isolate any high switching noise from the outputs to the internal PLL.  $V_{CC}$ ,  $V_{CCA}$  and  $V_{CCO}$  should be individually connected to the power supply plane through vias, and bypass capacitors should be used for each pin. To achieve optimum jitter performance, power supply isolation is required. *Figure 2* illustrates how a  $10\Omega$  resistor along with a  $10\mu\text{F}$  and a  $0.01\mu\text{F}$  bypass capacitor should be connected to each  $V_{CCA}$  pin.

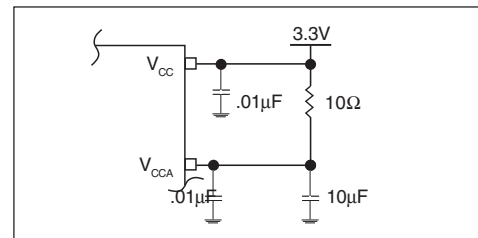

FIGURE 2. POWER SUPPLY FILTERING

### WIRING THE DIFFERENTIAL INPUT TO ACCEPT SINGLE ENDED LEVELS

*Figure 3* shows how the differential input can be wired to accept single ended levels. The reference voltage  $V_{REF} = V_{CC}/2$  is generated by the bias resistors R1, R2 and C1. This bias circuit should be located as close as possible to the input pin. The ratio

of R1 and R2 might need to be adjusted to position the  $V_{REF}$  in the center of the input voltage swing. For example, if the input clock swing is only 2.5V and  $V_{CC} = 3.3\text{V}$ ,  $V_{REF}$  should be 1.25V and  $R2/R1 = 0.609$ .

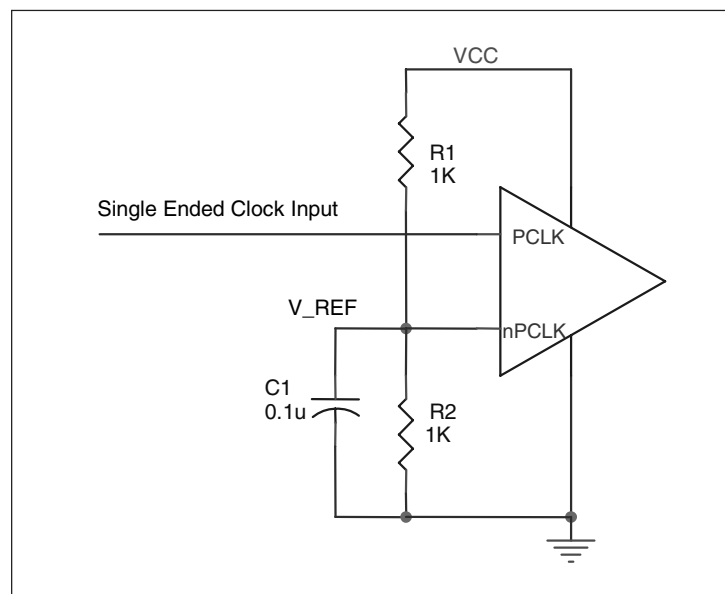
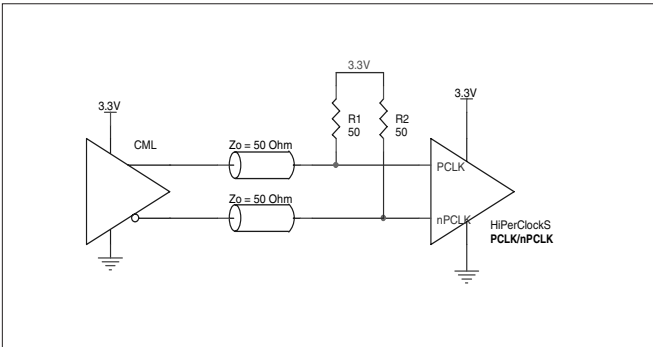

FIGURE 3. SINGLE ENDED SIGNAL DRIVING DIFFERENTIAL INPUT

**LVPECL CLOCK INPUT INTERFACE**

The PCLK/nPCLK accepts LVPECL, CML, SSTL and other differential signals. Both  $V_{SWING}$  and  $V_{OH}$  must meet the  $V_{PP}$  and  $V_{CMR}$  input requirements. Figures 4A to 4E show interface examples for the HiPerClockS PCLK/nPCLK input driven by the most common driver types. The input interfaces suggested

here are examples only. If the driver is from another vendor, use their termination recommendation. Please consult with the vendor of the driver component to confirm the driver termination requirements.



**FIGURE 4A. HiPerClockS PCLK/nPCLK INPUT DRIVEN BY AN OPEN COLLECTOR CML DRIVER**

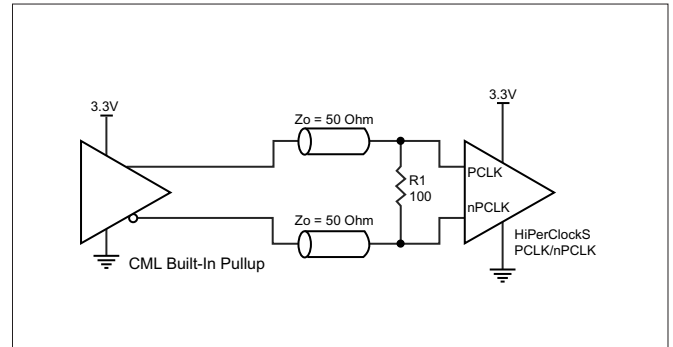

**FIGURE 4B. HiPerClockS PCLK/nPCLK INPUT DRIVEN BY A BUILT-IN PULLUP CML DRIVER**

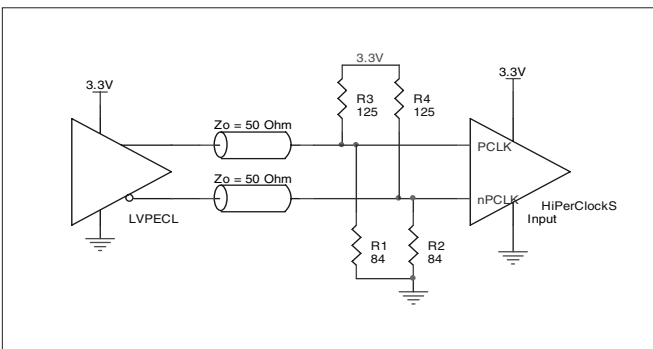

**FIGURE 4C. HiPerClockS PCLK/nPCLK INPUT DRIVEN BY A 3.3V LVPECL DRIVER**

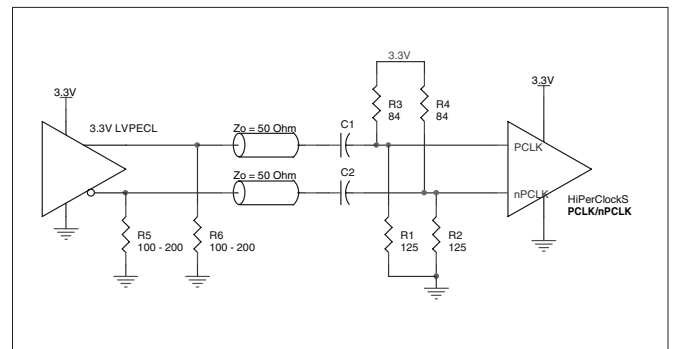

**FIGURE 4D. HiPerClockS PCLK/nPCLK INPUT DRIVEN BY A 3.3V LVPECL DRIVER WITH AC COUPLE**

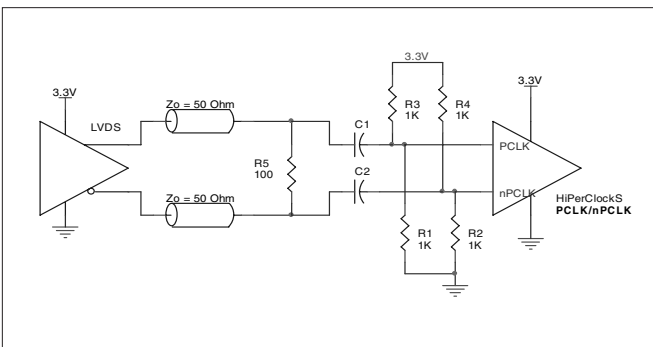

**FIGURE 4E. HiPerClockS PCLK/nPCLK INPUT DRIVEN BY A 3.3V LVDS DRIVER**

## RECOMMENDATIONS FOR UNUSED INPUT AND OUTPUT PINS

### INPUTS:

#### PCLK/nPCLK INPUTS

For applications not requiring the use of a differential input, both the PCLK and nPCLK pins can be left floating. Though not required, but for additional protection, a 1k $\Omega$  resistor can be tied from PCLK to ground.

#### LVCMOS CONTROL PINS

All control pins have internal pull-ups or pull-downs; additional resistance is not required but can be added for additional protection. A 1k $\Omega$  resistor can be used.

### OUTPUTS:

#### LVPECL OUTPUTS

All unused LVPECL outputs can be left floating. We recommend that there is no trace attached. Both sides of the differential output pair should either be left floating or terminated.

## TERMINATION FOR LVPECL OUTPUTS

The clock layout topology shown below is a typical termination for LVPECL outputs. The two different layouts mentioned are recommended only as guidelines.

FOUT and nFOUT are low impedance follower outputs that generate ECL/LVPECL compatible outputs. Therefore, terminating resistors (DC current path to ground) or current sources must be used for functionality. These outputs are designed to

drive 50 $\Omega$  transmission lines. Matched impedance techniques should be used to maximize operating frequency and minimize signal distortion. *Figures 5A and 5B* show two different layouts which are recommended only as guidelines. Other suitable clock layouts may exist and it would be recommended that the board designers simulate to guarantee compatibility across all printed circuit and clock component process variations.

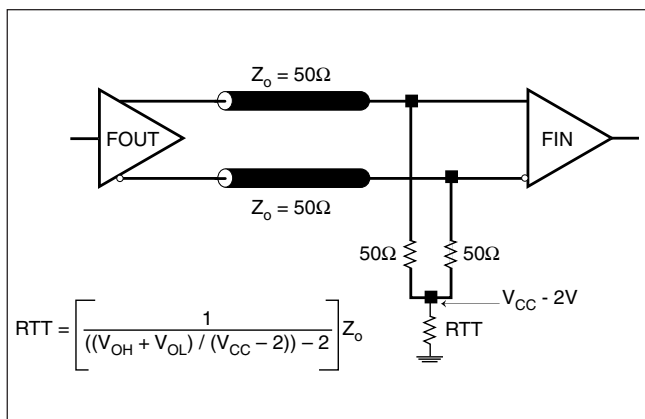

FIGURE 5A. LVPECL OUTPUT TERMINATION

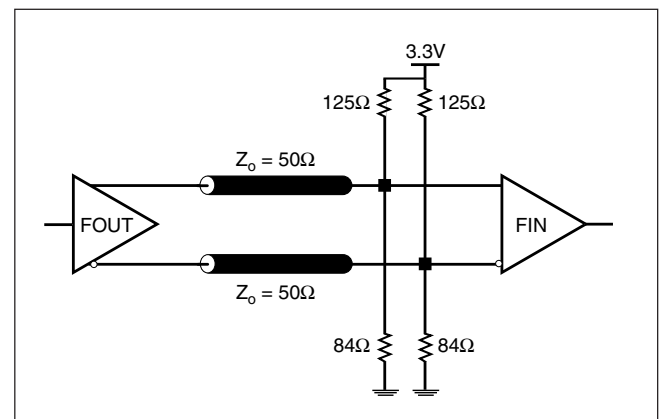

FIGURE 5B. LVPECL OUTPUT TERMINATION

## POWER CONSIDERATIONS

This section provides information on power dissipation and junction temperature for the ICS873991-147. Equations and example calculations are also provided.

### 1. Power Dissipation.

The total power dissipation for the ICS873991-147 is the sum of the core power plus the power dissipated in the load(s). The following is the power dissipation for  $V_{CC} = 3.3V + 5\% = 3.465V$ , which gives worst case results.

**NOTE:** Please refer to Section 3 for details on calculating power dissipated in the load.

- Power (core)<sub>MAX</sub> =  $V_{CC\_MAX} * I_{EE\_MAX} = 3.465V * 150mA = 519.75mW$
- Power (outputs)<sub>MAX</sub> = **30mW/Loaded Output pair**  
If all outputs are loaded, the total power is  $14 * 30mW = 420mW$

**Total Power**<sub>MAX</sub> (3.465V, with all outputs switching) =  $519.75mW + 420mW = 939.75mW$

### 2. Junction Temperature.

Junction temperature,  $T_j$ , is the temperature at the junction of the bond wire and bond pad and directly affects the reliability of the device. The maximum recommended junction temperature for HiPerClockS™ devices is 125°C.

The equation for  $T_j$  is as follows:  $T_j = \theta_{JA} * Pd\_total + T_A$

$T_j$  = Junction Temperature

$\theta_{JA}$  = Junction-to-Ambient Thermal Resistance

$Pd\_total$  = Total Device Power Dissipation (example calculation is in section 1 above)

$T_A$  = Ambient Temperature

In order to calculate junction temperature, the appropriate junction-to-ambient thermal resistance  $\theta_{JA}$  must be used. Assuming a moderate air flow of 1 meter per second and a multi-layer board, the appropriate value is 55.5°C/W per Table 7 below.

Therefore,  $T_j$  for an ambient temperature of 70°C with all outputs switching is:

$$70^\circ C + 0.940W * 55.5^\circ C/W = 122.2^\circ C. \text{ This is below the limit of } 125^\circ C.$$

This calculation is only an example.  $T_j$  will obviously vary depending on the number of loaded outputs, supply voltage, air flow, and the type of board (single layer or multi-layer).

**TABLE 7. THERMAL RESISTANCE  $\theta_{JA}$  FOR 52-PIN LQFP FORCED CONVECTION**

	$\theta_{JA}$ by Velocity (Meters per Second)		
	0	1	2.5
Multi-Layer PCB, JEDEC Standard Test Boards	63.7°C/W	55.5°C/W	52.4°C/W

### 3. Calculations and Equations.

The purpose of this section is to derive the power dissipated into the load.

LVPECL output driver circuit and termination are shown in *Figure 6*.

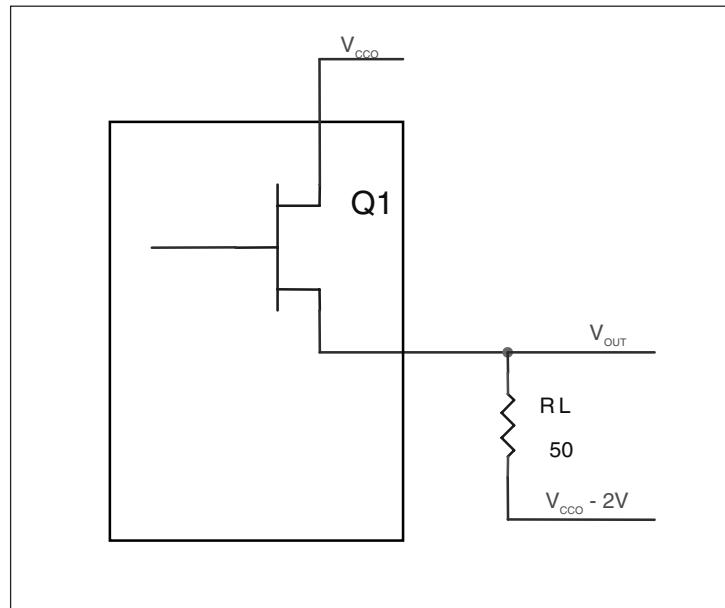

**FIGURE 6. LVPECL DRIVER CIRCUIT AND TERMINATION**

To calculate worst case power dissipation into the load, use the following equations which assume a 50Ω load, and a termination voltage of  $V_{CCO} - 2V$ .

- For logic high,  $V_{OUT} = V_{OH\_MAX} = V_{CCO\_MAX} - 0.9V$

$$(V_{CCO\_MAX} - V_{OH\_MAX}) = 0.9V$$

- For logic low,  $V_{OUT} = V_{OL\_MAX} = V_{CCO\_MAX} - 1.7V$

$$(V_{CCO\_MAX} - V_{OL\_MAX}) = 1.7V$$

$Pd\_H$  is power dissipation when the output drives high.

$Pd\_L$  is the power dissipation when the output drives low.

$$Pd\_H = [(V_{OH\_MAX} - (V_{CCO\_MAX} - 2V))/R_L] * (V_{CCO\_MAX} - V_{OH\_MAX}) = [(2V - (V_{CCO\_MAX} - V_{OH\_MAX}))/R_L] * (V_{CCO\_MAX} - V_{OH\_MAX}) = [(2V - 0.9V)/50\Omega] * 0.9V = 19.8mW$$

$$Pd\_L = [(V_{OL\_MAX} - (V_{CCO\_MAX} - 2V))/R_L] * (V_{CCO\_MAX} - V_{OL\_MAX}) = [(2V - (V_{CCO\_MAX} - V_{OL\_MAX}))/R_L] * (V_{CCO\_MAX} - V_{OL\_MAX}) = [(2V - 1.7V)/50\Omega] * 1.7V = 10.2mW$$

Total Power Dissipation per output pair =  $Pd\_H + Pd\_L = 30mW$

## RELIABILITY INFORMATION

**TABLE 8.  $\theta_{JA}$  VS. AIR FLOW TABLE FOR 52 LEAD LQFP**

	$\theta_{JA}$ by Velocity (Meters per Second)		
	0	1	2.5
Multi-Layer PCB, JEDEC Standard Test Boards	63.7°C/W	55.5°C/W	52.4°C/W

### TRANSISTOR COUNT

The transistor count for ICS873991-147 is: 5969

PACKAGE OUTLINE - Y SUFFIX FOR 52 LEAD LQFP

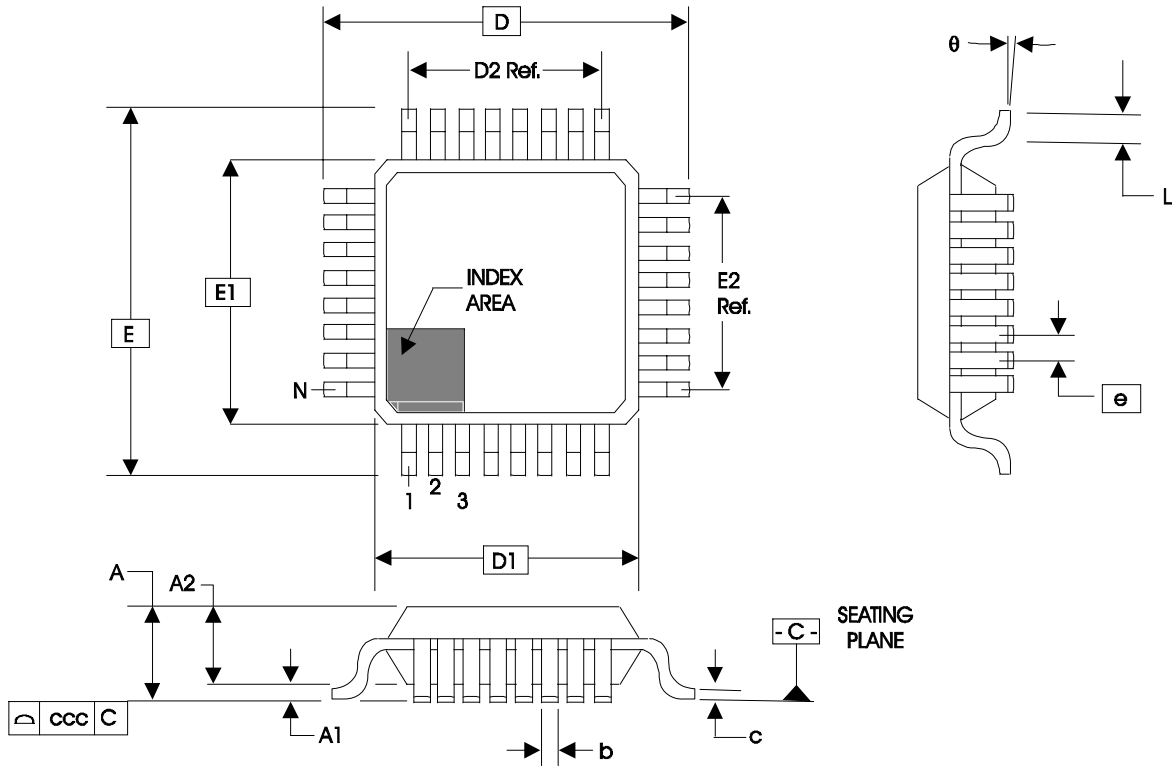

TABLE 9. PACKAGE DIMENSIONS

SYMBOL	JEDEC VARIATION ALL DIMENSIONS IN MILLIMETERS		
	BCC		
	MINIMUM	NOMINAL	MAXIMUM
N	52		
A	--	--	1.60
A1	0.05	--	0.15
A2	1.35	1.40	1.45
b	0.22	0.32	0.38
c	0.09	--	0.20
D	12.00 BASIC		
D1	10.00 BASIC		
D2	7.80 Ref.		
E	12.00 BASIC		
E1	10.00 BASIC		
E2	7.80 Ref.		
e	0.65 BASIC		
L	0.45	--	0.75
θ	0°	--	7°
ccc	--	--	0.10

Reference Document: JEDEC Publication 95, MS-026

TABLE 10. ORDERING INFORMATION

Part/Order Number	Marking	Package	Shipping Packaging	Temperature
873991AY-147LF	ICS873991A147L	52 Lead "Lead-Free" LQFP	tray	0°C to 70°C
873991AY-147LFT	ICS873991A147L	52 Lead "Lead-Free" LQFP	500 tape & reel	0°C to 70°C

NOTE: Parts that are ordered with an "LF" suffix to the part number are the Pb-Free configuration and are RoHS compliant.

While the information presented herein has been checked for both accuracy and reliability, Integrated Device Technology, Incorporated (IDT) assumes no responsibility for either its use or for infringement of any patents or other rights of third parties, which would result from its use. No other circuits, patents, or licenses are implied. This product is intended for use in normal commercial applications. Any other applications such as those requiring extended temperature ranges, high reliability or other extraordinary environmental requirements are not recommended without additional processing by IDT. IDT reserves the right to change any circuitry or specifications without notice. IDT does not authorize or warrant any IDT product for use in life support devices or critical medical instruments.



Innovate with IDT and accelerate your future networks. Contact:

[www.IDT.com](http://www.IDT.com)

**For Sales**

800-345-7015  
408-284-8200  
Fax: 408-284-2775

**For Tech Support**

[netcom@idt.com](mailto:netcom@idt.com)  
480-763-2056

---

**Corporate Headquarters**

Integrated Device Technology, Inc.  
6024 Silver Creek Valley Road  
San Jose, CA 95138  
United States  
800 345 7015  
+408 284 8200 (outside U.S.)

**Asia Pacific and Japan**

Integrated Device Technology  
Singapore (1997) Pte. Ltd.  
Reg. No. 199707558G  
435 Orchard Road  
#20-03 Wisma Atria  
Singapore 238877  
+65 6 887 5505

**Europe**

IDT Europe, Limited  
321 Kingston Road  
Leatherhead, Surrey  
KT22 7TU  
England  
+44 (0) 1372 363 339  
Fax: +44 (0) 1372 378851

